



# 6800 SERIES RIGID MOUNT TONGUE JACK



**WARNING** READ INSTRUCTIONS CAREFULLY BEFORE ATTEMPTING TO INSTALL, OPERATE OR SERVICE THIS JACK. FAILURE TO COMPLY WITH INSTRUCTIONS COULD RESULT IN SERIOUS INJURY. RETAIN THESE INSTRUCTIONS FOR FUTURE REFERENCE.

## ASSEMBLY & MOUNTING

Place the jack on the trailer tongue as near to the coupler as convenient. (See Fig. 1.) Make sure that jack does not interfere with other parts of the trailer or vehicle. Tighten all bolts evenly.

**NOTE:** This tongue jack fits 2", 3", 4", or 5" rectangular trailer tongues up to 3" wide. Tongues wider than 3" require replacement of existing mounting bolts with bolts of appropriate length. Mounting on a round tongue requires modification of the tongue to provide a rectangular area.

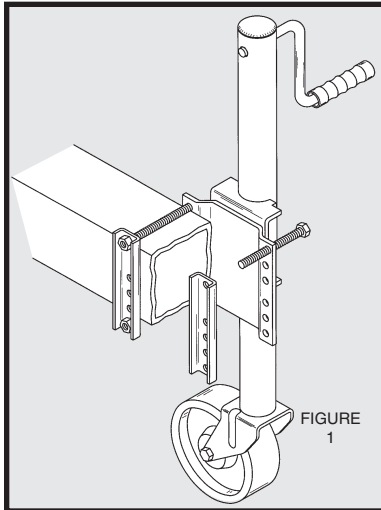

## OPERATION

Raise trailer by cranking jack clockwise and lower by cranking counterclockwise. When jack reaches the end of its travel **do not force handle**. To do so will result in damage. When maneuvering your trailer with weight on the jack, keep the jack cranked to the lowest possible position to avoid unnecessary strain. Do not use the jack or jack handle as a convenient hand hold for maneuvering the entire trailer. Avoid rolling the jack over rough or soft surfaces. Before towing the trailer, be sure jack is raised completely to give maximum road clearance.

On the drop leg model, cranking can be minimized by extending the drop leg to the desired amount. Be certain the lynch pin is fully engaged and latched before using jack.

**CAUTION!** Loads in excess of labeled capacity will cause accelerated wear on the jack parts and possible failure.

**CAUTION!** This jack is not for highway use, never tow trailer with a load on the jack.

**CAUTION!** Avoid cranking jack to unnecessary height and avoid side loads on jack that could cause damage or excessive wear.

## MAINTENANCE

Minimal maintenance is required to keep your Tongue Jack looking new and in good working order. Protect the finish by keeping it clean and periodically applying a coating of wax. Lubrication is needed if the jack ever feels rough or produces a grinding noise when cranked. With weight off the jack remove plastic cap. Remove pin (1) holding handle in place. Carefully remove bevel gear (2) on top of screw. Remove dowel pin (3) located under bevel gear. Carefully remove inner tube assembly. Do not attempt to remove screw from inner tube. Lubricate screw by working grease into entire thread. Reassemble and grease bevel gears.

**CE UK CA** **EC Declaration of Conformity –**  
Dutton-Lainson Company, Hastings, NE  
68902-0729 U.S.A. manufactures and declares that the winch identified above fulfills all relevant provisions of the Directive 2006/42/EC, and Supply of Machinery (Safety) Regulations 2008. The technical file may be obtained from the persons listed below.

Hastings, NE USA  
March 13, 2026  
  
Director of Engineering  
Dutton-Lainson Company

Kennard Kemperman  
Eurowarehouse BV  
De Amstel 11  
8253PC Dronten  
The Netherlands



A Dependable Company Since 1886  
**DUTTON-LAINSON COMPANY**  
Hastings, NE 68902 U.S.A. • Tel 402-462-4141 • Fax 402-460-4612  
www.dutton-lainson.com • E-mail: dlsales@dutton-lainson.com

MADE IN  
U.S.A.

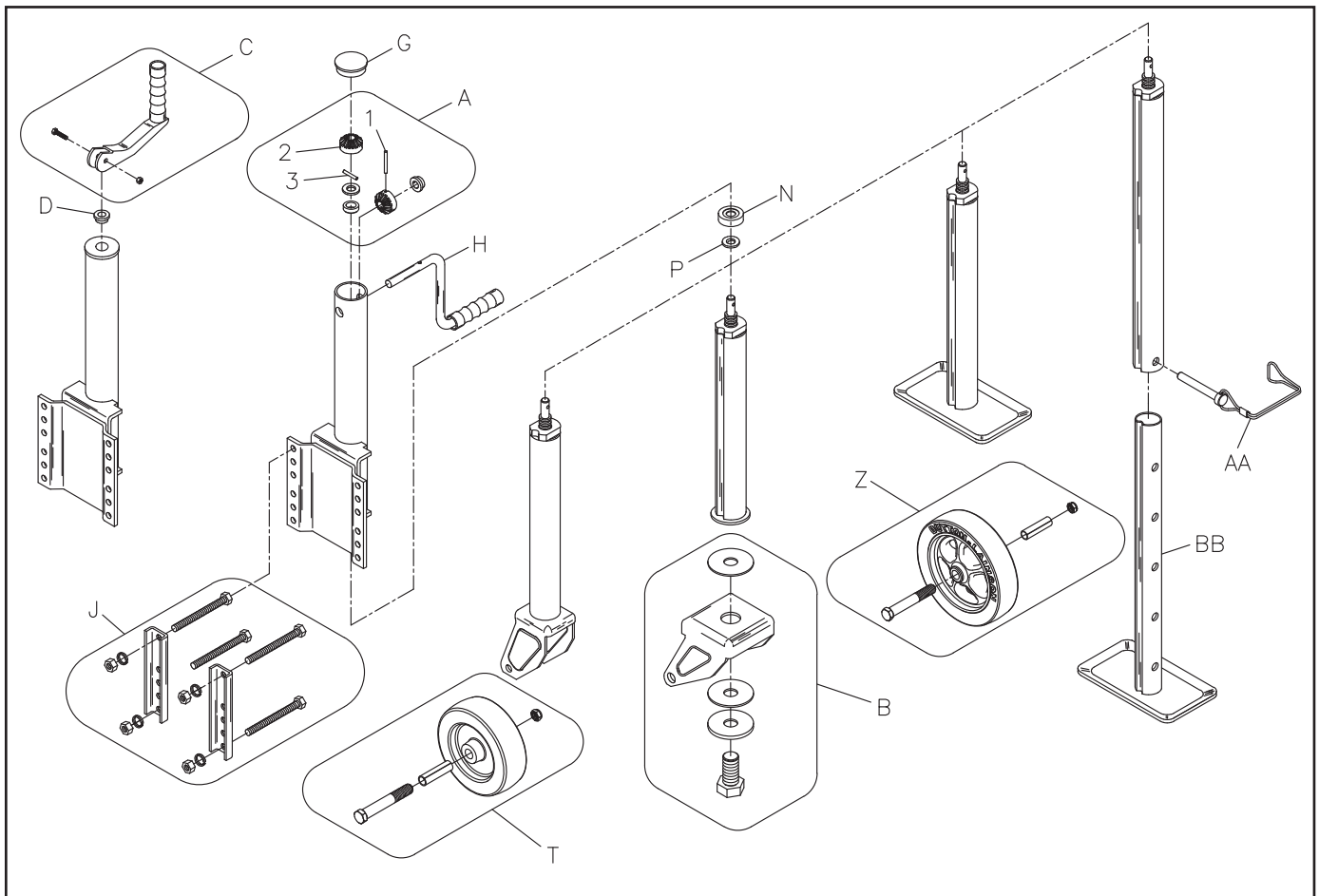

REF.	DESCRIPTION	PART NO.	REF.	DESCRIPTION	PART NO.	REF.	DESCRIPTION	PART NO.
A	6813A Miter Gear Kit	5224399	H	Jack Handle Assy w/Pin (6811A)	5224480	AA	Lynch Pin	203902
B	8" Wheel Bracket Ass'y	5226386	J	6804 Clamp & Bolt Kit	5224431	BB	Drop Leg Post	303563
B	6" Wheel Bracket Ass'y	5226360	N	Thrust Bearing	207121			
C	6619 Handle Kit	5226741	P	Flat Washer	207120			
D	Sintered Iron Bearing	204006	T	6" Poly Wheel (6805)	5224118			
G	Plastic End Cap	5226287	Z	8" Wheel (6807)	5224100			

To order replacement parts: **Contact: Dutton-Lainson Company,**  
 Tel: 800-569-6577, Fax: 402-460-4612, e-mail: DLsales@dutton-lainson.com

## LIMITED THREE (3) YEAR WARRANTY

Dutton-Lainson Company provides the following three (3) year limited warranty to the **original consumer purchaser** of D-L® trailer jacks and ag/ industrial jacks:

Dutton-Lainson Company will, at its option, repair or replace free-of-charge any part or parts found to be defective in material or workmanship under normal use for the period of three (3) years from the original purchase date or, if that date cannot be established, the date of manufacture. This includes a warranty against operational failure for the same three year period due to rust or corrosion of the TUFFPLATE® finish. This warranty is void if the product has been subject to alteration or damage, or is defective due to service or repair. This warranty does not assure that the product shall remain useable for the three (3) year warranty period since the life of the product is dependent upon the manner and the frequency of use.

Repair or replacement is the purchaser's sole remedy under this or any other warranty on the product, whether express or implied. **Dutton-Lainson Company shall not be liable for any incidental or consequential damages of any kind. Dutton-Lainson Company expressly disclaims any implied warranty of merchantability or fitness for particular purpose after the three (3) year warranty period.** Some states do not allow the exclusion or limitation of incidental or consequential damages and some states do not allow limitation on how long an implied warranty lasts, so the above exclusions and limitations may not apply to you.

To make a claim, contact Dutton-Lainson Company, Hastings, Nebraska 68902-0729, U.S.A., identify the product, and follow the instructions for return, which will be provided. Repair or replacement of the product, if found to be defective, will normally be completed within sixty (60) days after the receipt. The purchaser will be responsible for shipping costs to the Company.

This warranty gives you specific legal rights, and you may have other rights which vary from state-to-state.

This warranty is governed by the laws of the State of Nebraska except as modified by the laws of the U.S.A. and is void in countries where prohibited.