

BRAKE WINCHES

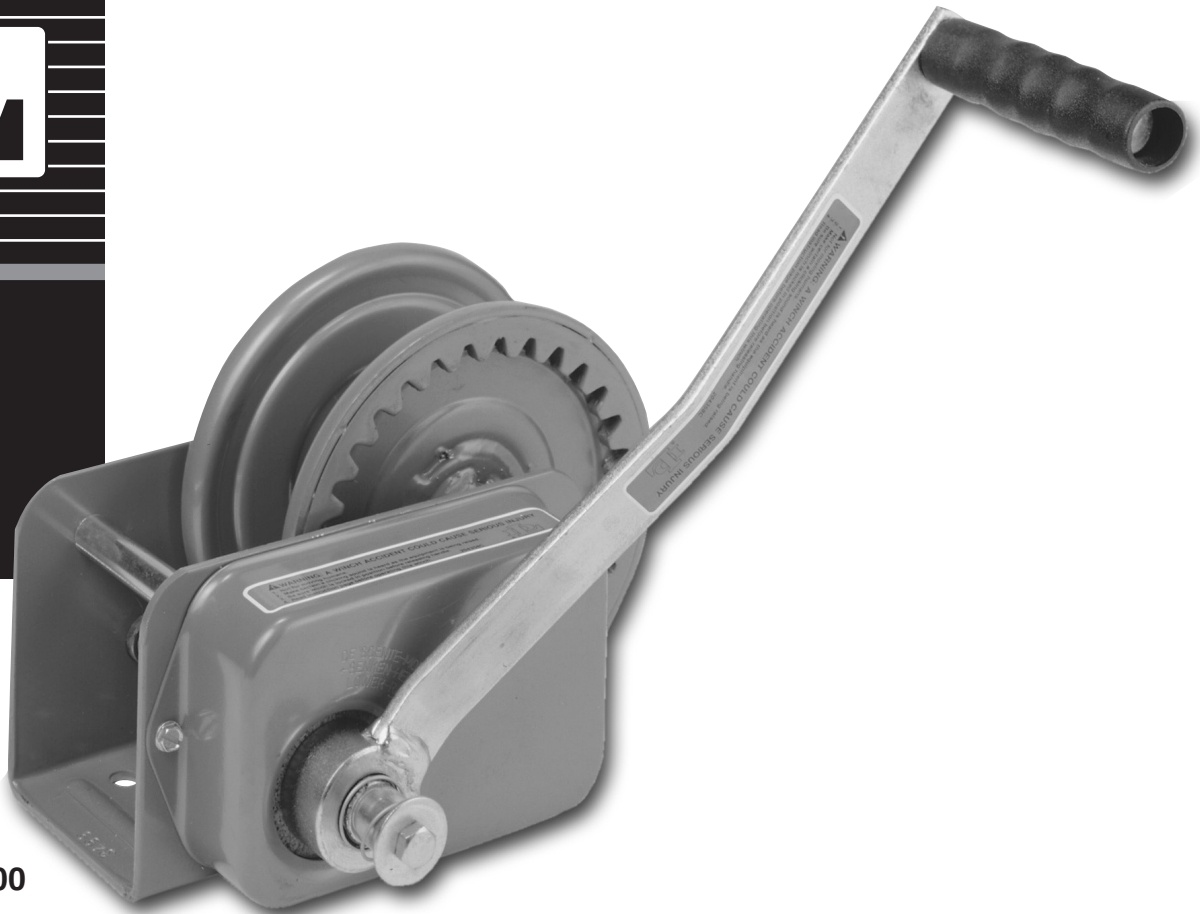

B1500

B1200B

B2500

B1200G

B2500G

B1500

B3500

B1500G



A Dependable Company Since 1886

DUTTON-LAINSON COMPANY

Hastings, NE 68902 U.S.A • Tel 402-462-4141 • Fax 402-460-4612

E-mail dlsales@dutton-lainson.com • Web Site www.dutton-lainson.com

ISO 9001 Certified Q.M.S.

**MADE IN
USA**

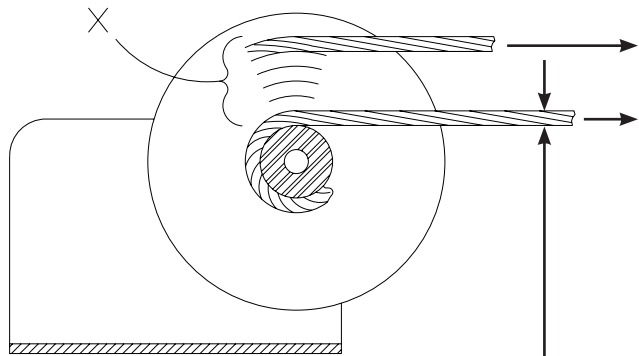

	"X"	
B1200B, B1200G	6	650 lb/295 kg
	1	1200 lb/544 kg
B1500, B1500G	6	728 lb/330 kg
	1	1500 lb/680 kg
B2500, B2500G	3	1554 lb/705 kg
	1	2500 lb/1134 kg
B3500	3	2172 lb/985 kg
	1	3500 lb/1588 kg

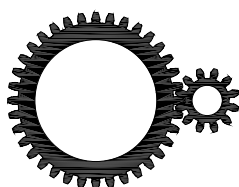

B1200B B1200G	4:1
B1500 B1500G	6:1
B2500 B2500G	12:1
B3500	18.75:1

B1200B	7/32" (5600 lb) x 57'
B1200G	5mm (1640 kg) x 12.3m
B1500	1/4" (7000 lb) x 52'
B1500G	6mm (2040 kg) x 11.4m
B2500	5/16" (9800 lb) x 51'
B2500G	8mm (3410 kg) x 7.4m
B3500	3/8" (14400 lb) x 28'



ENGLISH – DECLARATION OF CONFORMITY - Dutton-Lainson Company, Hastings, NE 68902-0729 U.S.A. manufactures and declares that the winch identified above fulfills all relevant provisions of the Directive 2006/42/EC, and Supply of Machinery (Safety) Regulations 2008. 'G' models also conform to harmonized standards EN 13157 and EN ISO 12100. The technical file may be obtained from the persons listed below.

DEUTSCH – KONFORMITÄTSEKTLÄRUNG - Dutton-Lainson Company, Hastings, NE 68902-0729, USA, der Hersteller der Winde, erklärt, dass die oben angegebene Winde alle relevanten Bestimmungen der Richtlinie 2006/42/EG erfüllt. Die 'G'-Modelle entsprechen außerdem den harmonisierten Normen EN 13157 und EN ISO 12100. Die technischen Unterlagen sind bei den nachfolgend aufgeführten Personen erhältlich.

FRANÇAIS – DÉCLARATION DE CONFORMITÉ - Dutton-Lainson Company, Hastings, NE 68902-0729 U.S.A. construit le treuil mentionné ci-dessus et déclare qu'il répond à toutes les dispositions applicables de la Directive 2006/42/CE. Les modèles 'G' sont également conformes aux normes harmonisées EN 13157 et EN ISO 12100. Le dossier technique peut être obtenu auprès des personnes indiquées ci-dessous.

ITALIANO – DICHIARAZIONE DI CONFORMITÀ - Il fabbricante, Dutton-Lainson Company, Hastings, NE 68902-0729 USA, dichiara che il verricello di cui sopra è conforme alle disposizioni della direttiva 2006/42/CE e che i modelli 'G' sono inoltre conformi alle norme armonizzate EN 13157 e EN ISO 12100. Il fascicolo tecnico può essere richiesto agli individui indicati qui di seguito.

ESPAÑOL – DECLARACION DE HOMOLOGACION - Dutton-Lainson Company, de Hastings, NE 68902-0729 EE.UU., fabrica y declara que el cabrestante arriba identificado satisface todas las provisiones pertinentes de la directriz 2006/42/EC. Los modelos 'G' también satisfacen las normas armonizadas EN 13157 y EN ISO 12100. El archivo técnico puede obtenerse de las personas mencionadas a continuación.

NEDERLANDS – VERKLARING VAN OVEREENSTEMMING - Dutton-Lainson Company, Hastings, NE 68902-0729 VS, fabrikant, verklaart dat de bovengenoemde lier voldoet aan alle betreffende bepalingen van richtlijn 2006/42/EC. 'G' modellen voldoen ook aan de geharmoniseerde normen EN 13157 en EN ISO 12100. Het technische bestand kan bij de hierna vermelde personen worden aangevraagd.

DANSK – OVERENSSTEMMELSESEKTLÄRUNG - Dutton-Lainson Company, Hastings, NE 68902-0729 USA fremstiller og erklærer, at skraldespillet identificeret ovenfor er i overensstemmelse med alle relevante krav i direktiv 2006/42/EU. "G" modeller er ligeledes i overensstemmelse med de harmoniserede standarder EN 13157 og EN ISO 12100. Den tekniske fil kan rekvireres gennem de nedennævnte personer.

NORSK – SAMSVARSEKTLÄRUNG - Dutton-Lainson Company, Hastings, NE 68902-0729 U.S.A. produserer og erklærer at vinsjen angitt ovenfor oppfyller alle relevante krav i direktivet 2006/42/EC. "G"-modellene samsvarer også med de harmoniserte standardene EN 13157 og EN ISO 12100. Den tekniske filen kan skaffes fra personene som er opplistet nedenfor.

SUOMI – VAATIMUSTENMUKAISUUSVAKUUTUS - Dutton-Lainson Company, osoite Hastings, NE 68902-0729 U.S.A, vakuuttaa tämän vintturin valmistajana, että tämä vintturi noudattaa direktiivin 2006/42/EY olennaisia määräyksiä. G-mallit ovat myös harmonisoiitujen standardien EN 13157:n ja EN ISO 12100 mukaisia. Tekniset tiedot on saatavissa alla ilmoitetuilta henkilöiltä.

SVENSKA – FÖRSÄKRAN OM ÖVERENSSTÄMMELSE - Dutton-Lainson Company, Hastings, Nebraska 68902-0729 U.S.A, tillverkar och försäkrar att denna vinsch överensstämmer med alla tillämpliga bestämmelser i Direktiv 2006/42/EC. 'G'-modeller är också förenliga med samordnade normer EN 13157 och EN ISO 12100. Den tekniska filen kan erhållas från de personer, som upptas nedan.

ΕΛΛΗΝΙΚΑ – ΔΗΛΩΣΗ ΣΥΜΜΟΡΦΩΣΗΣ - Η Dutton-Lainson Company, Hastings, NE 68902-0729 U.S.A. κατασκευάζει και δηλώνει ότι το βαρούλκο που καθορίζεται παραπάνω πληροί όλες τις σχετικές διατάξεις της Οδηγίας 2006/42/ΕΚ. Τα μοντέλα 'G' επίσης συμμορφώνονται με τα εναρμονισμένα πρότυπα EN 13157 και EN ISO 12100. Ο τεχνικός φάκελος είναι διαθέσιμος από τα άτομα τα οποία αναγράφονται παρακάτω.

PORTUGUÊS – DECLARAÇÃO DE CONFORMIDADE - A empresa Dutton-Lainson Company, Hastings, NE 68902-0729, nos E.U.A., fabrica o guincho acima identificado e declara que este cumpre todas as provisões relevantes da Directiva 2006/42/CE. Os modelos "G" cumprem também as normas harmonizadas EN 13157 e EN ISO 12100. Poderá obter o processo técnico junto das pessoas indicadas abaixo.

Hastings, NE USA
March 29, 2022

Jeff Dobbin

Director of Engineering
Dutton-Lainson Company

Jack Singleton
Eurowarehouse BV
De Amstel 11
8253PC Dronen
The Netherlands



WARNING READ INSTRUCTIONS CAREFULLY BEFORE ATTEMPTING TO INSTALL, OPERATE OR SERVICE THIS WINCH. FAILURE TO COMPLY WITH INSTRUCTIONS COULD RESULT IN SERIOUS OR FATAL INJURY. RETAIN THESE INSTRUCTIONS FOR FUTURE REFERENCE.



IMPORTANT SAFETY INFORMATION

- This brake winch is built for multi-purpose hauling and lifting operations. It is not to be used as a hoist for lifting, supporting or transporting people, or for loads over areas where people could be present.
- Respect this winch. High forces are created when using a winch, creating potential safety hazards. It should be operated and maintained in accordance with instructions. Never allow children or anyone who is not familiar with the operation of the winch to use it. A winch accident could result in personal injury.
- Check winch for proper operation on each use. Do not use if damaged. Seek immediate repairs.
- Never exceed rated capacity. Excess load may cause premature failure and could result in serious personal injury. This winch is rated

on third layer of cable on drum with drum size of 1-5/16" or less. It is rated on first layer of cable on drum with drum size of 2-1/2" or more. Using more layers of cable increases the load on the winch.

- Never apply load on winch with cable fully extended. Keep at least three full turns of cable on the reel. Check cable on every use. Replace at the first sign of kinks, broken wires, deformation or any other damage.
- Secure load properly. When winching operation is complete, do not depend on winch to support load.
- Operate with hand power only. This winch must not be operated with a motor of any kind. If the winch cannot be cranked easily with one hand, it is probably overloaded.

ASSEMBLY – Thread the handle onto the winch drive shaft and be certain that a clicking noise is produced when the handle is turned clockwise. Install the spring, shaft extension, washer and bolt on the end of the drive shaft as shown on parts drawing. These parts may appear to serve no function, but they provide several important fail-safe features, and must not be altered or removed.

WINCH MOUNTING AND CABLE ATTACHMENT – For maximum strength and safety, this winch must be mounted with three 3/8" bolts (M10), washers and lock washers. Use Grade 8 for 1500 lb./680 kg or greater capacity. (See parts drawing). Position winch so that cable approaches from reel end as shown.

Attach cable or rope by method described in sketch.

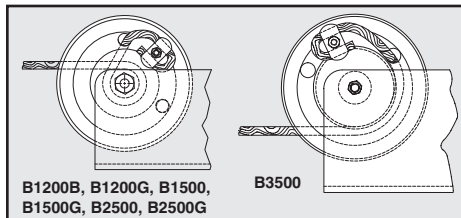

OPERATING INSTRUCTIONS – Wind cable on winch reel by turning winch handle in clockwise direction. This should produce a loud, sharp, clicking noise. The load will remain in position when the handle is released. Wind cable off the winch reel by turning winch handle counterclockwise (no noise will be produced). The load will remain in position when the handle is released, but for extra security it is recommended that the handle be turned clockwise until at least two clicks are heard. This will add extra tightness to the brake mechanism. Always satisfy yourself that the winch is holding the load before releasing the winch handle.

IMPORTANT: Sufficient load must be applied to the cable to overcome internal resistance and operate the brake properly; otherwise turning the crank handle counterclockwise will only remove the handle from the shaft – the reel will not turn. The minimum operating load requirement is 75 lbs. (34 kg) for Models B1200B & B1200G, 150 lbs. (68 kg) for B1500 & B1500G, 300 lbs. (136 kg) for B2500 & B2500G and 500 lbs. (227 kg) for B3500.



NOT FOR THE MOVEMENT OF HUMAN BEINGS

WINCH MAINTENANCE – Keep winch in good working order. Damaged or severely-worn parts create unnecessary dangers and could result in personal injury or property damage. The winch requires periodic maintenance. The following check must be made at least once annually and more frequently when the winch is exposed to an environment which is particularly dirty or wet.

1. Remove all of the load from the winch so that there is slack in the cable. Remove the winch handle and gear cover for inspection of the winch gear train and brake mechanism. This requires removal of bolt #204213 along with the flat washer, spacer and spring and requires that the handle be unthreaded (counterclockwise direction) from the drive shaft. The gear cover can then be removed.
2. Examine the winch gear train and brake mechanism for any rust, corrosion or build up of debris which might be present. Grasp the ratchet pawl #404409 and lift it out of contact with the ratchet wheel. Remove the ratchet wheel #404408 and two brake plates #205123 from the drive shaft. **IMPORTANT!** Relax the spring tension on the ratchet pawl paying particular attention to the attachment of the pawl to the spring and the amount of tension in the spring.
3. Check the entire gear train for any abnormal wear and be sure that the entire gear train turns freely. Grease all of the gear teeth with a good wheel bearing grease. Remove and grease reel bolt, reinstall reel bolt and tighten, making sure that reel shaft will not rotate in winch base.
4. Check the ratchet wheel, brake lining plates, winch handle hub and the washer on the drive shaft ass'y for any build up or glaze (shiny spots) which may be present. This can be removed by rubbing these parts

lightly with sand paper. **CAUTION!** Do not grease or oil any of the brake mechanism parts. Check the threads on the drive shaft ass'y and the threads in the handle hub to be sure that both are free of any rust or corrosion. Make sure that the handle runs freely onto the drive shaft thread without any binding whatsoever. Apply a small amount of grease to the threaded area to keep these parts moving freely.

5. Reassemble the two brake pads and the ratchet wheel onto the drive shaft while holding tension in the ratchet pawl. All of these parts should spin freely on the drive shaft. Be sure that the pawl properly engages with the teeth on the ratchet wheel. Thread the winch handle onto the drive shaft and check the operation of the winch. When cranking the handle in the clockwise direction, the ratchet wheel should turn with the shaft causing the pawl to snap in and out of the ratchet wheel teeth. In the counterclockwise direction the ratchet wheel should remain stationary while the handle turns.
6. Completely reassemble the winch gear cover, handle and all remaining parts. Check the mounting of the winch to be sure that it is secure and check the cable for any abnormal stiffness, kinking or broken strands. Replace the winch cable at the first sign of any damage. **NOTE:** Winch cable will last longer and remain more flexible with occasional application of light oil. The winch finish can be protected and will provide longer service if it is washed with water and then wiped with light oil or wax.

If you have any questions whatsoever concerning the above procedure, please contact the manufacturer.



B1200B & B1200G Winch

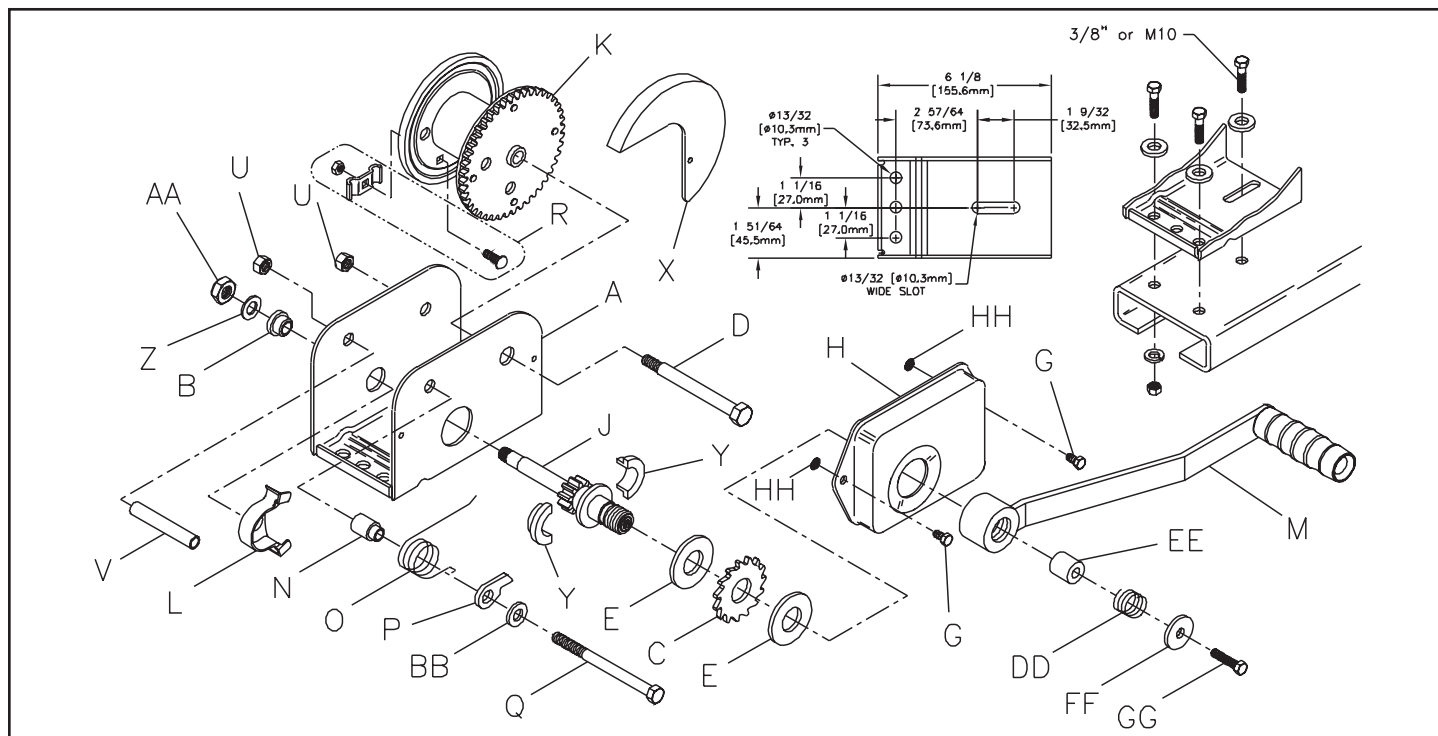

B1200B & B1200G Winch Parts List

Ref.	Description	Part No.	Ref.	Description	Part No.	Ref.	Description	Part No.
*A	Base (B1200B)	404943	M	Handle (B1200B)	5703509	V	Spacer	404371
A	Base (B1200G)	404944		w/Decal		X	Gear Cover - Opt. BZ	5240304
B	Bearing	204007	M	Handle (B1200G)	5146972	X	Gear Cover - Opt. PL	5240320
C	Ratchet Wheel	404408		w/Decal		Y	Bearing (2-Piece)	404952
D	Bolt	204805	N	Spacer	404368	Z	Washer	204360-PL
E	Pressure Plate (2)	205123	O	Spring (B1200B)	204142	AA	Locknut	205015
G	Screw (2)	205025	O	Spring (2) (B1200G)	204461	BB	Washer	205055
*H	Gear Cover	404362	P	Pawl	404409	DD	Spring	204212
J	Drive Shaft	304866	Q	Bolt	205126	EE	Shaft Extension	404122
*K	Reel - 1-1/8" Hub	304869	R	Rope Clamp Kit	5243506	FF	Washer	205119
*K	Reel - 2-1/2" Hub (B1200G)	304868	U	Locknut (2)	205270	GG	Bolt	204213
L	Gear Cover (B1200G)	406116				HH	Retainer (B1200G)	206589

*Specify Color When Ordering

- ENGLISH: WARNING:** Component parts should not be interchanged with the component parts of any other Dutton-Lainson model or other manufacturer's winches.
- DEUTSCH: ACHTUNG:** Die Komponenten dürfen nicht gegen andere Komponenten anderer Modelle der Dutton-Lainson Company oder der Winden anderer Hersteller ausgetauscht werden.
- FRANÇAIS: AVERTISSEMENT :** Ces composants ne doivent pas être utilisés de manière interchangeable avec les composants d'aucun autre modèle de Dutton-Lainson Company ou avec les treuils d'un autre fabricant.
- ITALIANO: AVVERTIMENTO:** Questi componenti non devono essere utilizzati in modo intercambiabile con i componenti di qualsiasi altro modello della Dutton-Lainson Company o con i verricelli di un altro fabbricante.
- ESPAÑOL: ADVERTENCIA:** No se debe intercambiar estas piezas con las de algún otro modelo de cabrestante de la Dutton-Lainson Company o de otro fabricante.
- NEDERLANDS: WAARSCHUWING:** Deze onderdelen mogen niet verwisseld worden met de onderdelen van andere liermodellen van Dutton-Lainson Company of van lieren van andere fabrikanten.

- DANSK: ADVARSEL:** Disse komponentdele må ikke blive udskiftet med komponentdele, der hører til andre modeller fra Dutton-Lainson Company eller til spil af andre fabrikater.
- NORSK: ADVARSEL:** Disse komponentdelene skal ikke byttes om med komponentdeler for noen annen vinsj verken fra Dutton-Lainson Company eller noen annen produsent.
- SUOMI: VAROITUS:** Tämän mallin ja muiden Dutton-Lainson Companyn tai muiden valmistajien vintturien osia ei saa vaihtaa keskenään.
- SVENSKA: VARNING:** Byt inte ut komponentdelarna mot komponentdelar från andra vinschar tillverkade av Dutton-Lainson Company eller från andra tillverkares vinschar (eller tvärtom).
- ΕΛΛΗΝΙΚΑ ΠΡΟΕΙΔΟΠΟΙΗΣΗ** Αυτά τα συνθετικά μέρη να μην αντικατασταθούν με συνθετικά μέρη άλλου μοντέλου της εταιρίας Δυττον-Λαινσον ή βαρούλκα άλλου εργοστασίου.
- PORTUGUÊS: ADVERTÊNCIA:** Esses componentes não devem ser intercambiados com componentes de nenhum outro modelo da Dutton-Lainson Company nem de guinchos de outros fabricantes.

To order replacement parts contact:

Dutton-Lainson Company

www.dlco.com

Tel: 800-569-6577

Fax: 402-460-4612

e-mail: DLsales@dutton-lainson.com



B1500 & B1500G Winch

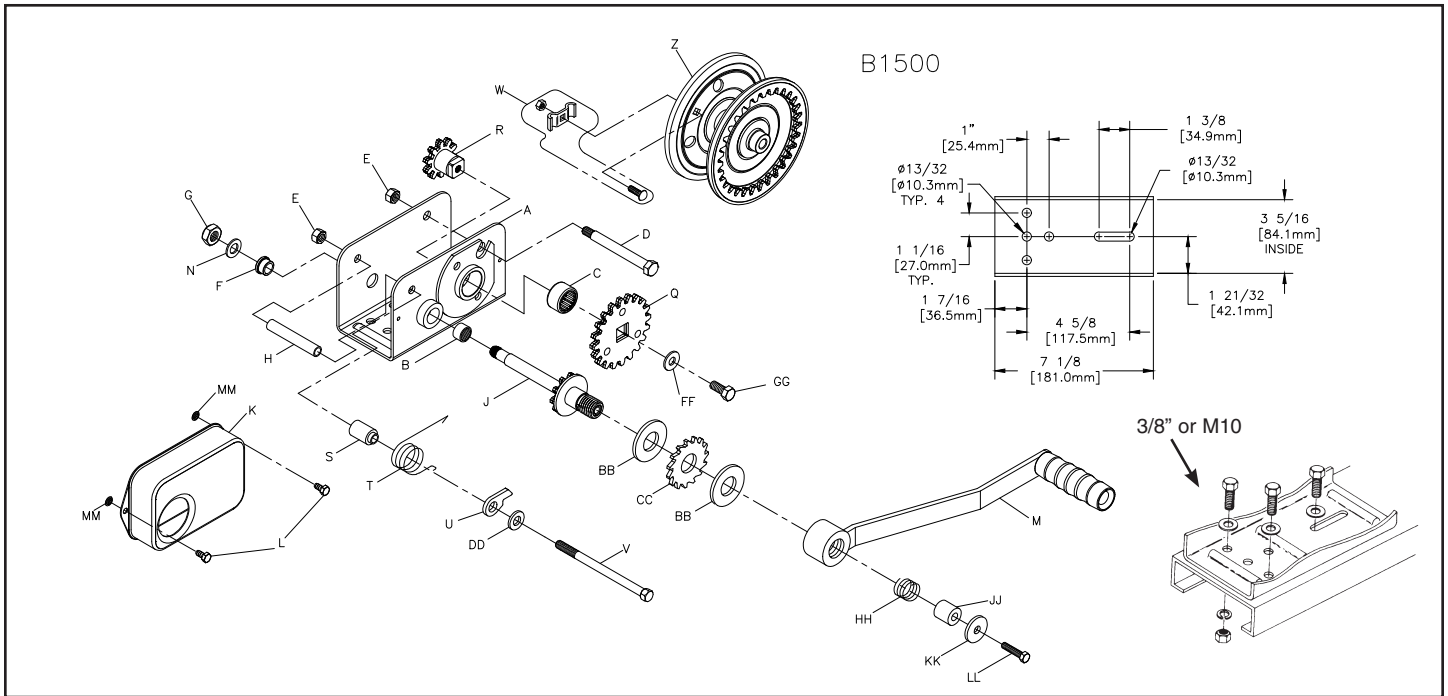

B1500 & B1500G Winch Parts List

Ref.	Description	Part No.	Ref.	Description	Part No.	Ref.	Description	Part No.
*A	Base (B1500)	304358	M	Handle (B1500)	5703509	W	Rope Clamp Kit	5243506
A	Base (B1500G)	304391		w/Decal		*Z	Reel - 1-1/8" Hub	304360
B	Bearing	205131	M	Handle (B1500G)	5146972	*Z	Reel - 2-1/2" Hub (B1500G)	304359
C	Bearing	205130		w/Decal		BB	Pressure Plate (2)	205123
D	Bolt	204805	N	Washer	204360-PL	CC	Ratchet Wheel	404408
E	Locknut (2)	205270	Q	Gear	304173	DD	Washer	205055
F	Bearing	204148	R	Drive Shaft	304169	FF	Washer	205044
G	Locknut	205015	S	Spacer	404369	GG	Bolt	205121
H	Spacer	404371	T	Spring (B1500)	204142	HH	Spring	204212
J	Drive Shaft	304163	T	Spring (2) (B1500G)	204461	JJ	Shaft Extension	404122
*K	Gear Cover	404363	U	Pawl	404409	KK	Washer	205119
L	Screw (2)	205025	V	Bolt (B1500)	205127	LL	Bolt	204213
			V	Bolt (B1500G)	205335	MM	Retainer (B1500G)	206589

*Specify Color When Ordering

- ENGLISH: WARNING:** Component parts should not be interchanged with the component parts of any other Dutton-Lainson model or other manufacturer's winches.
- DEUTSCH: ACHTUNG:** Die Komponenten dürfen nicht gegen andere Komponenten anderer Modelle der Dutton-Lainson Company oder der Winden anderer Hersteller ausgetauscht werden.
- FRANÇAIS: AVERTISSEMENT :** Ces composants ne doivent pas être utilisés de manière interchangeable avec les composants d'aucun autre modèle de Dutton-Lainson Company ou avec les treuils d'un autre fabricant.
- ITALIANO: AVVERTIMENTO:** Questi componenti non devono essere utilizzati in modo intercambiabile con i componenti di qualsiasi altro modello della Dutton-Lainson Company o con i verricelli di un altro fabbricante.
- ESPAÑOL: ADVERTENCIA:** No se debe intercambiar estas piezas con las de algún otro modelo de cabrestante de la Dutton-Lainson Company o de otro fabricante.
- NEDERLANDS: WAARSCHUWING:** Deze onderdelen mogen niet verwisseld worden met de onderdelen van andere liermodellen van Dutton-Lainson Company of van lieren van andere fabrikanten.

- DANSK: ADVARSEL:** Disse komponentdele må ikke blive udskiftet med komponentdele, der hører til andre modeller fra Dutton-Lainson Company eller til spil af andre fabrikater.
- NORSK: ADVARSEL:** Disse komponentdelene skal ikke byttes om med komponentdeler for noen annen vinsj verken fra Dutton-Lainson Company eller noen annen produsent.
- SUOMI: VAROITUS:** Tämän mallin ja muiden Dutton-Lainson Companyn tai muiden valmistajien vintturien osia ei saa vaihtaa keskenään.
- SVENSKA: VARNING:** Byt inte ut komponentdelarna mot komponentdelar från andra vinschar tillverkade av Dutton-Lainson Company eller från andra tillverkares vinschar (eller tvärtom).
- ΕΛΛΗΝΙΚΑ ΠΡΟΕΙΔΟΠΟΙΗΣΗ** Αυτά τα συνθετικά μέρη να μην αντικατασταθούν με συνθετικά μέρη άλλου μοντέλου της εταιρίας Δυττον-Λαινσον ή βαρούλκα άλλου εργοστασίου.
- PORTUGUÊS: ADVERTÊNCIA:** Esses componentes não devem ser intercambiados com componentes de nenhum outro modelo da Dutton-Lainson Company nem de guinchos de outros fabricantes.

To order replacement parts contact:

Dutton-Lainson Company

www.dlco.com

Tel: 800-569-6577

Fax: 402-460-4612

e-mail: DLsales@dutton-lainson.com



B2500 & B2500G Winch

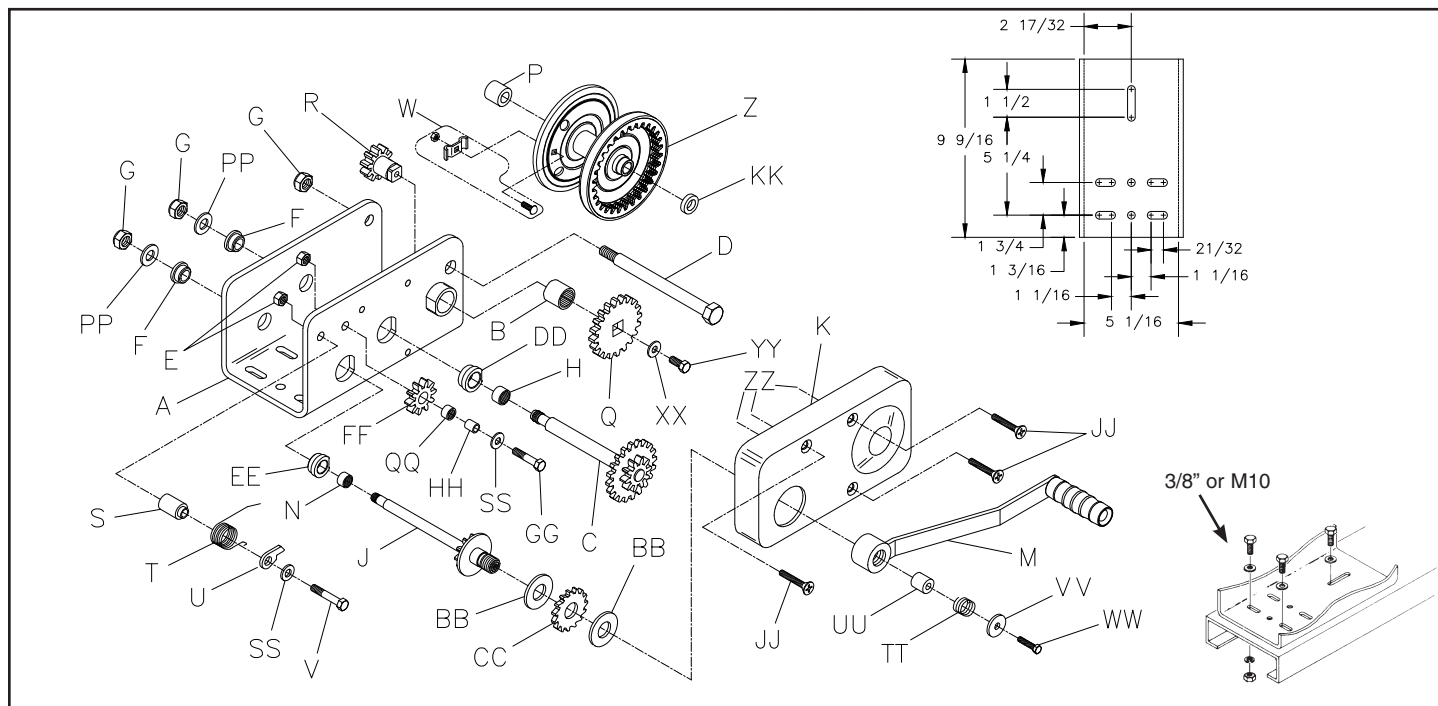

B2500 & B2500G Winch Parts List

Ref.	Description	Part No.	Ref.	Description	Part No.	Ref.	Description	Part No.
*A	Base (B2500)	304481	P	Spacer	404373	FF	Gear	304172
A	Base (B2500G)	304483	Q	Gear	304174	GG	Bolt	203136
B	Bearing	205133	R	Drive Shaft	304170	HH	Spacer	404996
C	Drive Shaft	304167	S	Spacer	404370	JJ	Screw (3)	205125
D	Bolt	204145	T	Spring (B2500)	204142	KK	Spacer	404372
E	Locknut (2)	205270	T	Spring (2) (B2500G)	204461	PP	Washer (2)	204360-PL
F	Bearing (2)	204148	U	Pawl	404409	QQ	Bearing	205134
G	Locknut (3)	205015	V	Bolt	205128	SS	Washer (2)	205055
H	Bearing	205183	W	Rope Clamp Kit	304321	TT	Spring	204212
J	Drive Shaft	304271	*Z	Reel 1-5/16" Hub	304156	UU	Shaft Extension	404122
*K	Gear Cover	404364	*Z	Reel 2-1/2" Hub	304160	VV	Washer	205119
M	Handle (B2500) w/Decal	5703509	*Z	Reel 3-1/8" Hub (B2500G)	304161	WW	Bolt	204213
M	Handle (B2500G) w/Decal	5146972	BB	Pressure Plate (2)	205123	XX	Washer	205044
N	Bearing	205131	CC	Ratchet Wheel	404408	YY	Bolt	205121
			DD	Housing	404476	ZZ	Retainer (B2500G)	206590
			EE	Housing	404479			

*Specify Color When Ordering

ENGLISH: WARNING: Component parts should not be interchanged with the component parts of any other Dutton-Lainson model or other manufacturer's winches.

DEUTSCH: ACHTUNG: Die Komponenten dürfen nicht gegen andere Komponenten anderer Modelle der Dutton-Lainson Company oder der Winden anderer Hersteller ausgetauscht werden.

FRANÇAIS: AVERTISSEMENT : Ces composants ne doivent pas être utilisés de manière interchangeable avec les composants d'aucun autre modèle de Dutton-Lainson Company ou avec les treuils d'un autre fabricant.

ITALIANO: AVVERTIMENTO: Questi componenti non devono essere utilizzati in modo intercambiabile con i componenti di qualsiasi altro modello della Dutton-Lainson Company o con i verricelli di un altro fabbricante.

ESPAÑOL: ADVERTENCIA: No se debe intercambiar estas piezas con las de algún otro modelo de cabrestante de la Dutton-Lainson Company o de otro fabricante.

NEDERLANDS: WAARSCHUWING: Deze onderdelen mogen niet verwisseld worden met de onderdelen van andere liermodellen van Dutton-Lainson Company of van lieren van andere fabrikanten.

DANSK: ADVARSEL: Disse komponentdele må ikke blive udskiftet med komponentdele, der hører til andre modeller fra Dutton-Lainson Company eller til spil af andre fabrikater.

NORSK: ADVARSEL: Disse komponentdelene skal ikke byttes om med komponentdeler for noen annen vinsj verken fra Dutton-Lainson Company eller noen annen produsent.

SUOMI: VAROITUS: Tämän mallin ja muiden Dutton-Lainson Companyn tai muiden valmistajien vintturien osia ei saa vaihtaa keskenään.

SVENSKA: VARNING: Byt inte ut komponentdelarna mot komponentdelar från andra vinschar tillverkade av Dutton-Lainson Company eller från andra tillverkares vinschar (eller tvärtom).

ΕΛΛΗΝΙΚΑ ΠΡΟΕΙΔΟΠΟΙΗΣΗ Αυτά τα συνθετικά μέρη να μην αντικατασταθούν με συνθετικά μέρη άλλου μοντέλου της εταιρίας Διττον-Λαινσον ή βαρούλκα άλλου εργοστασίου.

PORTUGUÊS: ADVERTÊNCIA: Esses componentes não devem ser intercambiados com componentes de nenhum outro modelo da Dutton-Lainson Company nem de guinchos de outros fabricantes.

To order replacement parts contact:

Dutton-Lainson Company

www.dlco.com

Tel: 800-569-6577

Fax: 402-460-4612

e-mail: DLsales@dutton-lainson.com



B3500 Winch

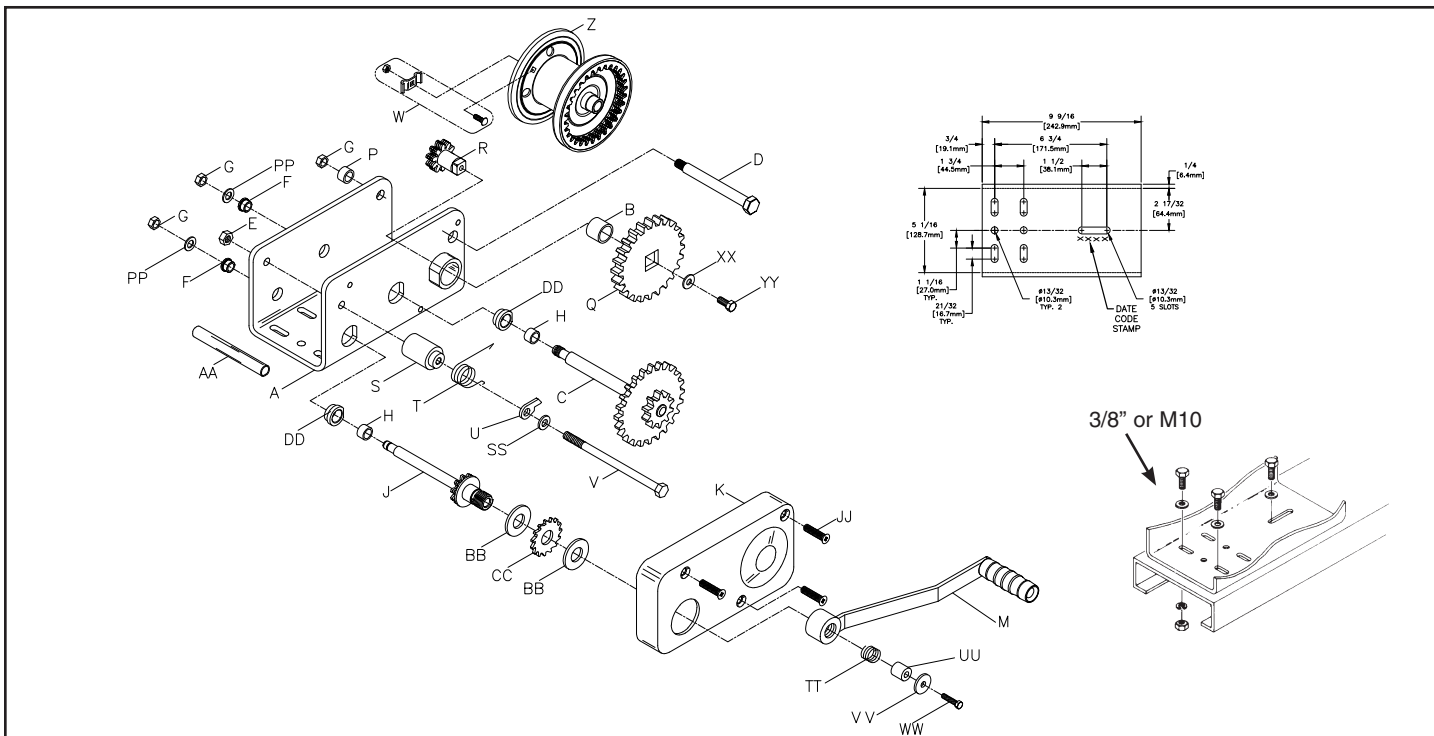

B3500 Winch Parts List

Ref.	Description	Part No.	Ref.	Description	Part No.	Ref.	Description	Part No.
A	Base	304604-PL	M	Handle w/Decal	5703509	AA	Spacer 2 pcs.	404371 & 404723
B	Bearing	205133	P	Spacer	404718	BB	Pressure Plate (2)	205123
C	Drive Shaft	304599	Q	Gear	304601	CC	Ratchet Wheel	404408
D	Bolt	204145	R	Drive Shaft	304194	DD	Housing (2)	404476
E	Locknut	205270	S	Spacer	404704	JJ	Screw (3)	205125
F	Bearing (2)	204148	T	Spring	204142	PP	Washer (2)	204360-PL
G	Locknut (3)	205015	U	Pawl	404409	SS	Washer	205055
H	Bearing (2)	205183	V	Bolt	404724	TT	Spring	204212
J	Drive Shaft	304595	W	Rope Clamp Kit	304321	UU	Shaft Extension	404122
K	Gear Cover	404703	Z	Reel 3-1/8" Hub	304603-BK	VV	Washer	205119
						WW	Bolt	204213
						XX	Washer	205044
						YY	Bolt	205121

ENGLISH: WARNING: Component parts should not be interchanged with the component parts of any other Dutton-Lainson model or other manufacturer's winches.

DEUTSCH: ACHTUNG: Die Komponenten dürfen nicht gegen andere Komponenten anderer Modelle der Dutton-Lainson Company oder der Winden anderer Hersteller ausgetauscht werden.

FRANÇAIS: AVERTISSEMENT : Ces composants ne doivent pas être utilisés de manière interchangeable avec les composants d'aucun autre modèle de Dutton-Lainson Company ou avec les treuils d'un autre fabricant.

ITALIANO: AVVERTIMENTO: Questi componenti non devono essere utilizzati in modo intercambiabile con i componenti di qualsiasi altro modello della Dutton-Lainson Company o con i verricelli di un altro fabbricante.

ESPAÑOL: ADVERTENCIA: No se debe intercambiar estas piezas con las de algún otro modelo de cabrestante de la Dutton-Lainson Company o de otro fabricante.

NEDERLANDS: WAARSCHUWING: Deze onderdelen mogen niet verwisseld worden met de onderdelen van andere liermodellen van Dutton-Lainson Company of van lieren van andere fabrikanten.

DANSK: ADVARSEL: Disse komponentdele må ikke blive udskiftet med komponentdele, der hører til andre modeller fra Dutton-Lainson Company eller til spil af andre fabrikater.

NORSK: ADVARSEL: Disse komponentdelene skal ikke byttes om med komponentdeler for noen annen vinsj verken fra Dutton-Lainson Company eller noen annen produsent.

SUOMI: VAROITUS: Tämän mallin ja muiden Dutton-Lainson Companyn tai muiden valmistajien vintturien osia ei saa vaihtaa keskenään.

SVENSKA: VARNING: Byt inte ut komponentdelarna mot komponentdeler från andra vinschar tillverkade av Dutton-Lainson Company eller från andra tillverkares vinschar (eller tvärtom).

ΕΛΛΗΝΙΚΑ ΠΡΟΕΙΔΟΠΟΙΗΣΗ Αυτά τα συνθετικά μέρη να μην αντικατασταθούν με συνθετικά μέρη άλλου μοντέλου της εταιρίας Δυττον-Λαινσον ή βαρούλκα άλλου εργοστασίου.

PORTUGUÊS: ADVERTÊNCIA: Esses componentes não devem ser intercambiados com componentes de nenhum outro modelo da Dutton-Lainson Company nem de guinchos de outros fabricantes.

To order replacement parts contact:

Dutton-Lainson Company

www.dlco.com

Tel: 800-569-6577

Fax: 402-460-4612

e-mail: DLsales@dutton-lainson.com

ENGLISH

To obtain a copy of the warranty in English, send a self-addressed envelope to: Dutton-Lainson Company; P.O. Box 729; Hastings NE 68902-0729; U.S.A.

DEUTSCH

Wenn Sie eine deutsche Kopie der Garantibestimmungen erhalten möchten, senden Sie bitte einen adressierten Rückumschlag an: Dutton-Lainson Company; P.O.Box 729; Hastings NE 68902-0729; USA

FRANÇAIS

Pour obtenir une copie de la garantie en français, envoyer une enveloppe à votre nom et adresse à : Dutton-Lainson Company; P.O. Box 729; Hastings NE 68902-0729; U.S.A.

ITALIANO

Per ricevere una copia della garanzia in italiano, inviare una busta riportante il proprio indirizzo a: Dutton-Lainson Company, P.O. Box 729, Hastings NE 68902-0729 USA.

ESPAÑOL

Para obtener una copia de la garantía en español, envíe un sobre con su dirección impresa a: Dutton-Lainson Company, P.O. Box 729; Hastings NE 68902-0729 EE.UU.

NEDERLANDS

Voor een exemplaar van de garantie in het Nederlands dient u een aan u zelf geadresseerde enveloppe te zenden naar: Dutton-Lainson Company; P.O. Box 729; Hastings NE 68902-0729; U.S.A.

DANSK

Man kan få garantibeviset på dansk ved at sende en svarkuvert til: Dutton-Lainson Company, P.O. Box 729, Hastings NE 68902-0729, USA.

NORSK

En kopi av denne garantien på norsk fås ved å sende en konvolutt med eget navn og adresse, til Dutton-Lainson Company, P.O. Box 729, Hastings NE 68902-0729, USA

SUOMI

Takuutodistuksesta saa suomenkielisen kopion lähettämällä riittäväällä postimaksulla ja vastaanottajan osoitteella varustetun kirjekuoren osoitteeseen Dutton-Lainson Company, P.O. Box 729, Hastings NE 68902-0729, USA.

SVENSKA

För att erhålla ett exemplar av garantin på svenska skicka ett adresserat kuvert till: Dutton-Lainson Company, P.O.Box 729, Hastings NE 68902-0729 U.S.A.

ΕΛΛΗΝΙΚΑ

Για να λάβετε ένα αντίγραφο της εγγύησης στα Ελληνικά, στείλτε ένα φάκελο εσωκλείοντας τα ταχυδρομικά τέλη αποστολής στην εξής διεύθυνση: Dutton-Lainson Company, P.O. Box 729, Hastings, NE 68902-0729, U.S.A.

PORTUGUÊS

Para obter uma cópia da garantia em português, envie um envelope com a sua morada para: Dutton-Lainson; P. O. Box 729; Hastings NE 68902-0729; E.U.A.



Printed by:  **CORNHUSKER** ©2021
PRESS SINCE 1935
Hastings • Grand Island • Kearney
A DIVISION OF DUTTON-LAINSON COMPANY