

Model 6560 Hand Winch Cover

(Fits Dutton-Lainson Hand Winch Model DL1402A)

INSTALLATION INSTRUCTIONS

To assemble the hand winch cover to your winch, some disassembly of the winch is required.

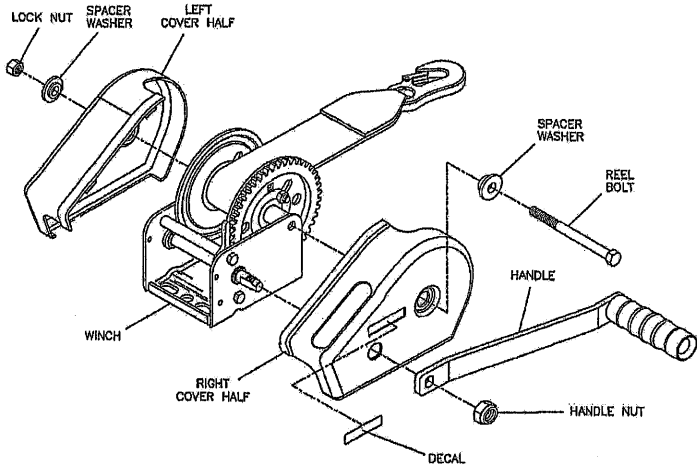

1. Remove the handle nut and handle from your winch.
2. Remove the locknut from the reel bolt and remove the reel bolt from the winch. Position the right cover half onto the winch making sure the ratchet lever fits through the slot provided.
3. Place a spacer washer onto the reel bolt making sure flat side of spacer washer is against bolt head as shown in the drawing and reassembly through cover half and winch as shown. **Note:** To assure smooth performance of the winch, it's a good idea to remove the sleeve in the winch reel and grease the center hole of the reel before re-assembly.
4. Place the left cover half over the winch (this cover half should fit and mate into the right cover half) and place other spacer washer onto end of reel bolt. **Note:** Extruded side of washer fits into hole of cover, flat side of washer is facing outward as shown in drawing.
5. Using new locknut supplied, tighten bolt and nut to 150 inch pounds. **Important:** Use new locknut supplied.
6. Apply decal to right half decal impression (1400lb/635kg for DL1402A model).

Drawing No.
206322E 1/22



1886
DUTTON-LAINSON COMPANY
Hastings, NE 68902 U.S.A. • Tel 402-462-4141 • Fax 402-460-4612
dlsales@dutton-lainson.com • www.dutton-lainson.com

ISO 9001 Certified Q.M.S.

