



StrongArm®

12 Volt DC

ELECTRIC WINCHES

REMOTE CONTROL INSTRUCTIONS

LOADING AND UNLOADING UNDER POWER

This StrongArm electric winch comes equipped with a built-in hand held remote. The remote switch cord allows user to operate winch from a location up to 10 feet away.

Be sure to read owner's manual enclosed and to pay particular attention to the important safety information. Read and follow all instructions in the manual with the exception of the 'loading and unloading under power' section. This section is replaced with the following:

1. Attach the plug end of the power supply (wiring harness) into the connector located at the back of the winch. This pushes and snaps into place easily and will only fit in one direction. Connect the remote switch cord to the short cord coming from the back of the winch.
2. With the clutch lever in the 'engaged gears' position, you may power the winch in either the 'IN' or 'OUT' direction. The switch is spring loaded and will stop the winch and lock the load in position when switch is released. Leave your car engine running on fast idle as a precaution in case the battery is not in top condition.
3. Always disconnect the power when the winching operation is complete. To disconnect power supply, simply pull the plug end of power supply from the winch.

NOTE: It is normal for smoke to be produced during the initial power down use.

! WARNING: EVEN THOUGH THE WINCH IS EQUIPPED WITH CIRCUIT BREAKER OVERLOAD PROTECTION, PARTICULAR CARE SHOULD BE TAKEN NOT TO CREATE AN OVERLOAD. PAY ATTENTION TO THE SOUND OF THE WINCH AND THE LOAD BEING PULLED. MAKE CERTAIN THAT THE CABLE TENSION DOES NOT RISE SUDDENLY BECAUSE OF A BIND IN THE LOAD.

! CAUTION: The electric motor is designed for intermittent service only. Extended use without cooling off periods will cause overheating, resulting in motor damage. Maximum recommended continuous run time is four minutes.

4. When the unit is used to trailer a boat, secure the boat onto the trailer with appropriate bow and transom tie down straps or chains. With the boat fully secured on the trailer, it is advisable to relieve the tension on the winch cable to avoid damage to the winch and trailer due to high shock loads encountered when traveling.
5. Always disconnect the remote switch cord from the short cord on the winch when the winching operation is complete.

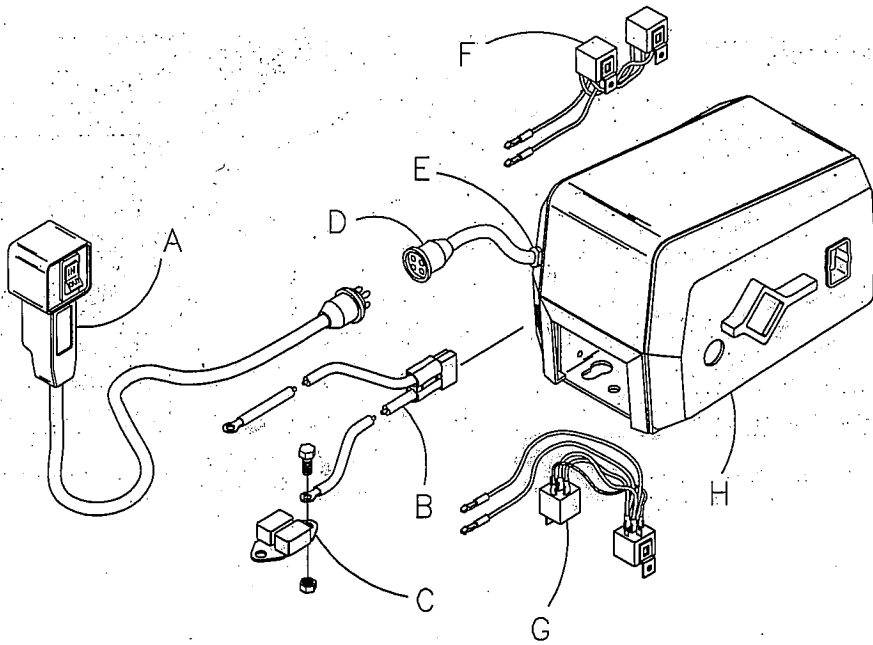

PARTS LIST		
Ref.	Part	Number
A	Switch Assy	304325
B	Wiring Harness (complete)	5241518
C	Circuit Breaker Assy	304025
D	Pigtail, 9"	304917
E	Strain Relief Bushing	205037
F	Relay Assy (SA5015/SA7015)	304971
G	Relay Assy (SA9015/SA12015)	304972
H	Cover (SA5015/SA7015)	404983
H	Cover (SA9015/SA12015)	404981
J	Motor Assy (not shown)	304973

Refer to owner's manual parts list for all other replacement parts.

WIRING DIAGRAM

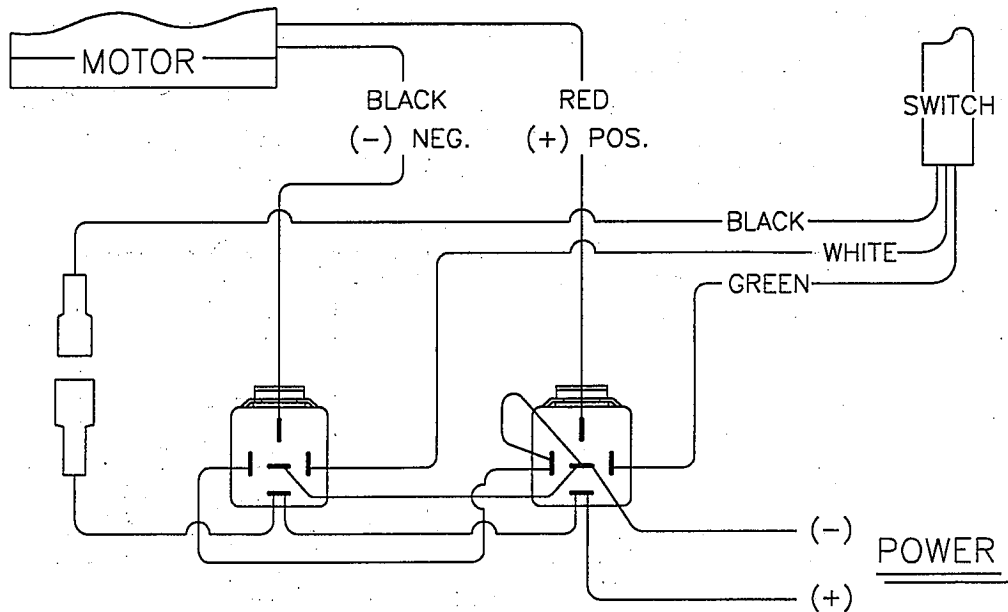

A Dependable Company Since 1886
DUTTON-LAINSON COMPANY
 Hastings, NE 68902 U.S.A. • Tel 402-462-4141 • Fax 402-460-4612
 www.dutton-lainson.com • E-mail: dlsales@dutton-lainson.com

MADE IN
U.S.A.