

DLC600, DLC1100



PULLING WINCHES



DLC1100



A Dependable Company Since 1886
DUTTON-LAINSON COMPANY
Hastings, NE 68902 U.S.A • Tel 402-462-4141 • Fax 402-460-4612
E-mail dlsales@dutton-lainson.com • Web Site www.dutton-lainson.com

ISO 9001 Certified Q.M.S.

**MADE IN
USA**

⚠ WARNING READ INSTRUCTIONS CAREFULLY BEFORE ATTEMPTING TO INSTALL, OPERATE OR SERVICE THIS WINCH. FAILURE TO COMPLY WITH INSTRUCTIONS COULD RESULT IN SERIOUS OR FATAL INJURY. RETAIN THESE INSTRUCTIONS FOR FUTURE REFERENCE.



IMPORTANT SAFETY INFORMATION

- This winch is built for multi-purpose hauling and pulling operations. It is not recommended for lifting applications. For lifting, use a self-locking winch. DL winches are not to be used as hoists for lifting, supporting or transporting people, or for loads over areas where people could be present.
- Respect this winch. High forces are created when using a winch, creating potential safety hazards. It should be operated and maintained in accordance with instructions. Never allow children or anyone who is not familiar with the operation of the winch to use it.
- Maintain a firm grip on the winch handle at all times, and never release the handle when ratchet lever is in unlocked position with a load on the winch. Otherwise, handle will spin violently, which could cause personal injury.
- Check for proper ratchet operation on each use of the winch. Do not use if damaged. Seek immediate repairs.
- Never use the winch handle as a convenient handle for pulling or maneuvering the entire trailer or other equipment. Never pull on the winch handle against a locked ratchet.
- Never exceed rated capacity. Excess load may cause premature failure and could result in serious personal injury. This winch is rated with three layers of line on the hub. Using more layers of line or a large hub increases the load on the winch.
- Never apply load on winch with cable or rope fully extended. Keep at least three full turns of cable or rope on the reel.
- Secure load properly. When winching operation is complete, do not depend on winch to support load.
- Operate with hand power only. This winch should not be operated with a motor of any kind. If the winch cannot be cranked easily with one hand, it is probably over-loaded.

WINCH MOUNTING AND CABLE ATTACHMENT

— For maximum strength and safety, (and compliance with SAE Standard J1853) this winch should be mounted with three 3/8" or M10 bolts, washers, and lock washers. (See parts drawing).

Select a winch line with breaking strength at least 1-1/2 times the winch rating and a hook 1-1/2" times stronger than the line. If steel cable is selected, the optional reel with large hub may extend cable life. (The above combination meets SAE Standard

J1853 for boat trailer winches).

Attach cable or rope by either method described in sketch. If nylon strap is used, it should have a loop sewn in one end and be attached using a 3/8" x 3" (DLC1100) or 1/4" x 2-3/4" (DLC600) long bolt and locknut. Use a locknut, not a nut and lockwasher. Insert bolt through slots in both reel sideplates so that nut is on gear side. Tighten only until snug with bolt in bottom of slot next to reel hub.

OPERATING INSTRUCTIONS

— HANDLE AND NUT MUST BE TIGHTENED AGAINST DRIVE SHAFT BEFORE OPERATING WINCH. Wind line on winch reel by turning winch handle in clockwise direction with ratchet lever in "on" position. The ratchet should produce a loud, sharp, clicking noise. Make sure that ratchet lever is in "on" position and holding load before winch handle is released. To unwind or reel out line, securely grip winch handle and apply force in clockwise direction so that ratchet lever can easily be moved to "off" position. Carefully turn handle in counterclockwise direction. Do not lose control.

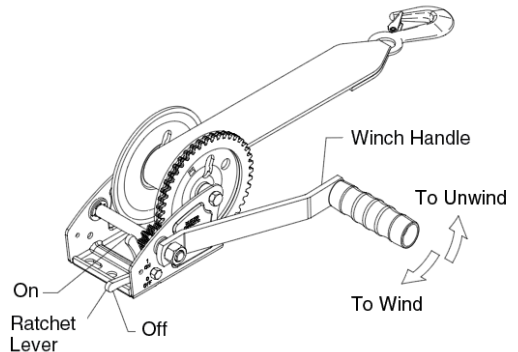

WINCH MAINTENANCE

— This winch has been fully lubricated at the factory; but, for continued smooth performance and increased life, occasional greasing of gears and reel shaft and an occasional drop of oil on drive shaft bearings are recommended.

Keep winch in good working order. Damaged or severely-worn parts create unnecessary dangers and could result in personal injury or property damage.



NOT FOR THE MOVEMENT OF HUMAN BEINGS

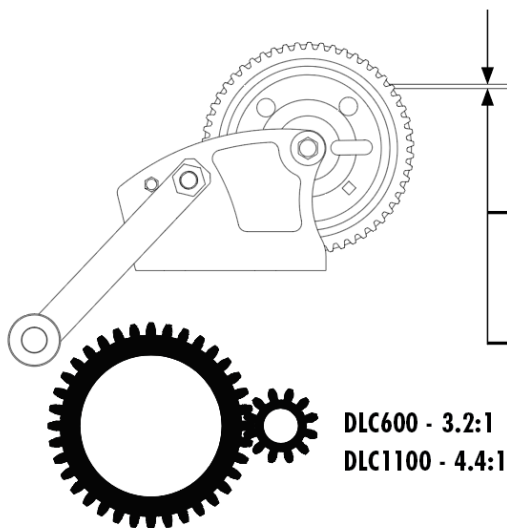

DLC600 - 600 lbs/272 kg
DLC1100 - 1100 lbs/499 kg

STRAP

DLC600 - 16' Standard Duty
DLC1100 - 29' Standard Duty

CABLE

DLC600 - 5/32" X 61' (4mm x 19.2m)
DLC1100 - 3/16" X 79' (5mm x 22.2m)



ENGLISH – DECLARATION OF CONFORMITY - Dutton-Lainson Company, Hastings, NE 68902-0729 U.S.A. manufactures and declares that the winch identified above fulfills all relevant provisions of the Directive 2006/42/EC, and Supply of Machinery (Safety) Regulations 2008. The technical file may be obtained from the persons listed below.

DEUTSCH – KONFORMITÄTSERKLÄRUNG - Dutton-Lainson Company, Hastings, NE 68902-0729, USA, der Hersteller der Winde, erklärt, dass die oben angegebene Winde alle relevanten Bestimmungen der Richtlinie 2006/42/EG erfüllt. Die technischen Unterlagen sind bei den nachfolgend aufgeführten Personen erhältlich.

ITALIANO – DICHIARAZIONE DI CONFORMITÀ - Il fabbricante, Dutton-Lainson Company, Hastings, NE 68902-0729 USA, dichiara che il verricello di cui sopra è conforme alle disposizioni della direttiva 2006/42/CE. Il fascicolo tecnico può essere richiesto agli individui indicati qui di seguito.

PORTUGUÊS – DECLARAÇÃO DE CONFORMIDADE - A empresa Dutton-Lainson Company, Hastings, NE 68902-0729, nos E.U.A., fabrica o guincho acima identificado e declara que este cumpre todas as provisões relevantes da Directiva 2006/42/CE. Poderá obter o processo técnico junto das pessoas indicadas abaixo.

ESPAÑOL – DECLARACION DE HOMOLOGACION - Dutton-Lainson Company, de Hastings, NE 68902-0729 EE.UU., fabrica y declara que el cabrestante arriba identificado satisface todas las provisiones pertinentes de la directriz 2006/42/EC. El archivo técnico puede obtenerse de las personas mencionadas a continuación.

SVENSKA – FÖRSÄKRAN OM ÖVERENSSTÄMMELSE - Dutton-Lainson Company, Hastings, Nebraska 68902-0729 U.S.A., tillverkar och försäkrar att denna vinsch överensstämmer med alla tillämpliga bestämmelser i Direktiv 2006/42/EC. Den tekniska filen kan erhållas från de personer, som upptas nedan.

DANSK – OVERENSSTEMMELSEERKLÆRING - Dutton-Lainson Company, Hastings, NE 68902-0729 USA fremstiller og erklærer, at skraldespillet identificeret ovenfor er i overensstemmelse med alle relevante krav i direktiv 2006/42/EU. Den tekniske fil kan rekvireres gennem de nedennævnte personer.

SUOMI – VAATIMUSTENMUKAISUUSVAKUUTUS - Dutton-Lainson Company, osoite Hastings, NE 68902-0729 U.S.A., vakuuttaa tämän vintturin valmistajana, että tämä vintturi noudattaa direktiivin 2006/42/EY olennaisia määräyksiä. Tekniset tiedot on saatavissa alla ilmoitetuilta henkilöiltä.

NORSK – SAMSVARERKLÆRING - Dutton-Lainson Company, Hastings, NE 68902-0729 U.S.A. produserer og erklærer at vinsjen angitt ovenfor oppfyller alle relevante krav i direktivet 2006/42/EC. Den tekniske filen kan skaffes fra personene som er opplistet nedenfor.

NEDERLANDS – VERKLARING VAN OVEREENSTEMMING - Dutton-Lainson Company, Hastings, NE 68902-0729 VS, fabrikant, verklaart dat de bovengenoemde lier voldoet aan alle betreffende bepalingen van richtlijn 2006/42/EC. Het technische bestand kan bij de hierna vermelde personen worden aangevraagd.

FRANÇAIS – DÉCLARATION DE CONFORMITÉ - Dutton-Lainson Company, Hastings, NE 68902-0729 U.S.A. construit le treuil mentionné ci-dessus et déclare qu'il répond à toutes les dispositions applicables de la Directive 2006/42/CE. Le dossier technique peut être obtenu auprès des personnes indiquées ci-dessous.

ΕΛΛΗΝΙΚΑ – ΔΗΛΩΣΗ ΣΥΜΜΟΡΦΩΣΗΣ - Dutton-Lainson Company, Hastings, NE 68902-0729 U.S.A. κατασκευάζει και δηλώνει ότι το βαρούλκο που καθορίζεται παραπάνω πληροί όλες τις σχετικές διατάξεις της Οδηγίας 2006/42/ΕΚ. Ο τεχνικός φάκελος είναι διαθέσιμος από τα άτομα τα οποία αναγράφονται παρακάτω.

Hastings, NE USA
April 28, 2023

Director of Engineering
Dutton-Lainson Company

Jack Singleton
Eurowarehouse BV
De Amstel 11
8253PC Dronten
The Netherlands



DLC600 & DLC1100

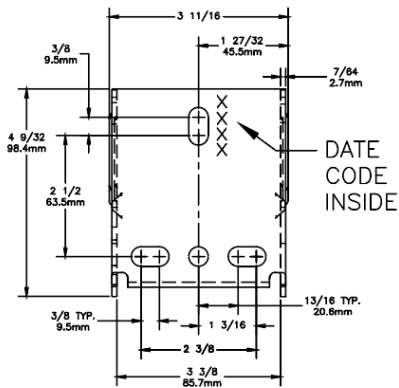
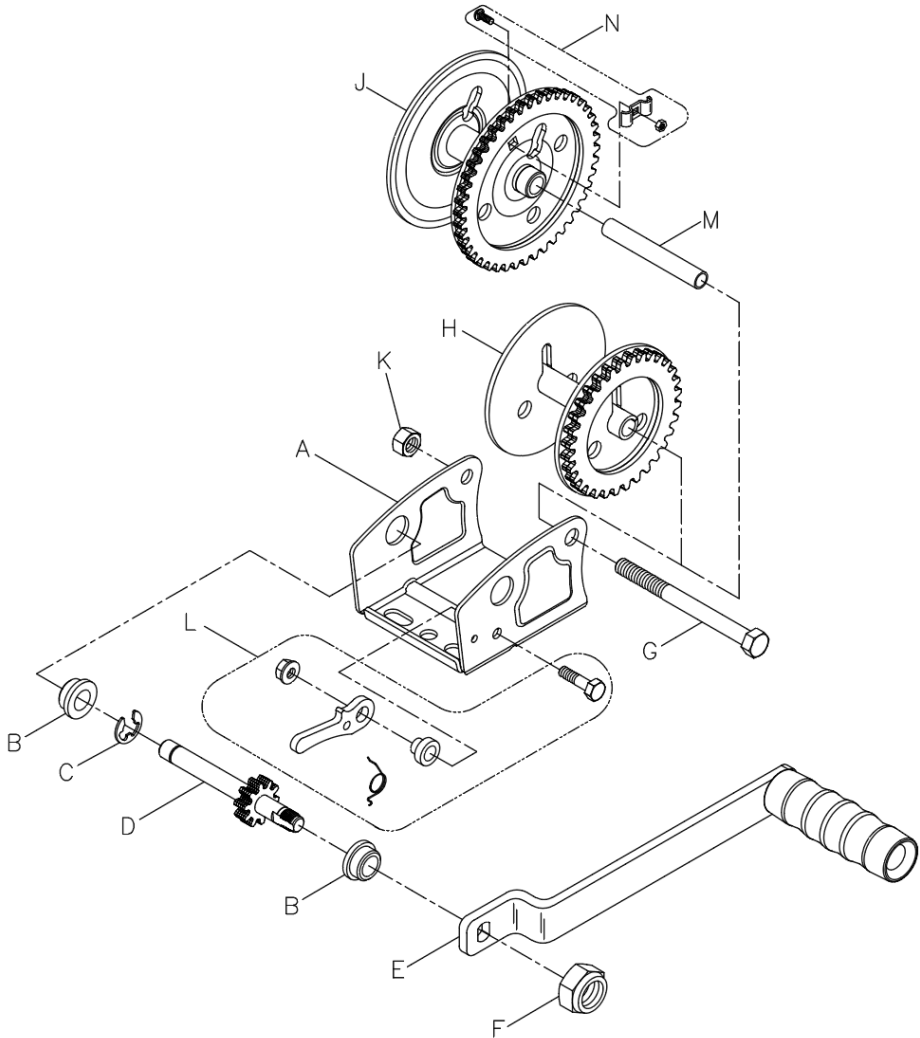

DLC600

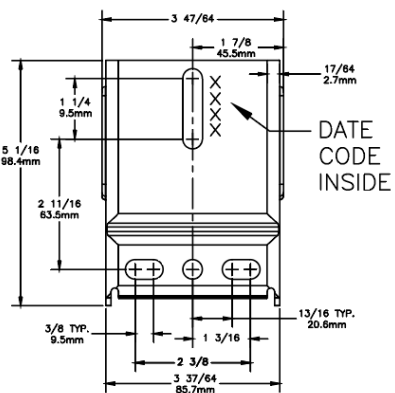

DLC1100

Ref	Description	Part No.
A	Base - DLC600	406277*
A	Base - DLC1100	406278*
B	Bushing (2)	204006
C	E-Ring	205012
D	Drive Shaft	306364
D	Drive Shaft (Threaded Both Ends) Opt.	306365
E	DLC Handle 7"	306360
E	DLC Handle 9"	306361
F	Nut	205015

Ref	Description	Part No.
G	Reel Shaft - DLC600	204805
G	Reel Shaft - DLC1100	205144
H	Reel (5/8" Hub) -DL600A	306363*
J	Reel (7/8" Hub) - DL1100A	304717*
J	Reel (1-1/4" Hub) - DL1100A	304752*
K	Locknut	204803
L	Ratchet Kit	5704531
M	Spacer - DLC1100	206072
N	Rope Clamp Kit	5243506

*Specify Color When Ordering

To order replacement parts contact:

Dutton-Lainson Company

www.dlco.com

Tel: 800-569-6577

Fax: 402-460-4612

e-mail: DLsales@dutton-lainson.com

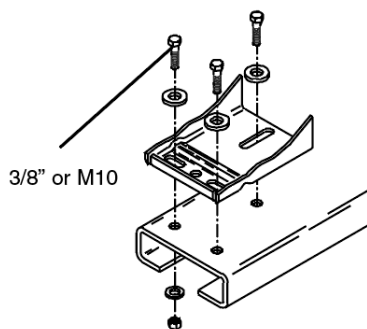
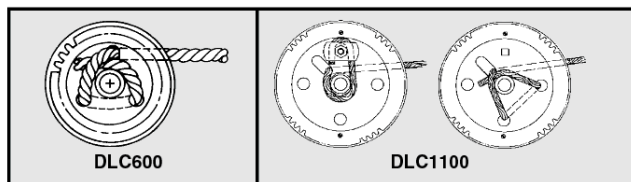

ENGLISH-To obtain a copy of the warranty in English, send a self-addressed envelope to: Dutton-Lainson Company; P.O. Box 729; Hastings NE 68902-0729; U.S.A.

DANSK-Man kan få garantibeviset på dansk ved at sende en svarkuvert til: Dutton-Lainson Company, P.O. Box 729, Hastings NE 68902-0729, USA.

SUOMI-Takuutodistuksesta saa suomenkielisen kopion lähettämällä riittävällä postimaksulla ja vastaanottajan osoitteella varustetun kirjekuoren osoitteeseen Dutton-Lainson Company, P.O. Box 729, Hastings NE 68902-0729, USA.

NEDERLANDS-Voor een exemplaar van de garantie in het Nederlands dient u een aan u zelf geadresseerde enveloppe te zenden naar: Dutton-Lainson Company; P.O. Box 729; Hastings NE 68902-0729; U.S.A.

FRANÇAIS-Pour obtenir une copie de la garantie en français, envoyer une enveloppe à votre nom et adresse à : Dutton-Lainson Company; P.O. Box 729; Hastings NE 68902-0729; U.S.A.

DEUTSCH-Wenn Sie eine deutsche Kopie der Garantibestimmungen erhalten möchten, senden Sie bitte einen adressierten Rückumschlag an: Dutton-Lainson Company; P.O.Box 729; Hastings NE 68902-0729; USA.

ITALIANO-Per ricevere una copia della garanzia in italiano, inviare una busta riportante il proprio indirizzo a: Dutton-Lainson Company, P.O. Box 729, Hastings NE 68902-0729 USA.

NORSK-En kopi av denne garantien på norsk fås ved å sende en konvolutt med eget navn og adresse, til Dutton-Lainson Company, P.O. Box 729, Hastings NE 68902-0729, USA.

PORTUGUÊS-Para obter uma cópia da garantia em português, envie um envelope com a sua morada para: Dutton-Lainson; P.O. Box 729; Hastings NE 68902-0729; E.U.A.

ESPAÑOL-Para obtener una copia de la garantía en español, envíe un sobre con su dirección impresa a: Dutton-Lainson Company, P.O. Box 729; Hastings NE 68902-0729 EE.UU.

SVENSKA-För att erhålla ett exemplar av garantin på svenska skicka ett adresserat kuvert till: Dutton-Lainson Company, P.O.Box 729, Hastings NE 68902-0729 U.S.A.

ΕΛΛΗΝΙΚΑ-Για να λάβετε ένα αντίγραφο της εγγύησης στα Ελληνικά, στείλτε ένα φάκελο εσωκλείοντας τα ταχυδρομικά τέλη αποστολής στην εξής διεύθυνση: Dutton-Lainson Company, P.O.Box 729, Hastings NE 68902-0729 U.S.A.